



PLANK

Fräsch was founded on the belief that creating healthy and beautiful office environments leads to a happier and highly motivated workforce.



PLANK

Acoustical Wall Tile

PLANK is a contemporary acoustical wall solution consisting of a series of slim PET boards that comes in two thickness options. Create many layouts with a shiplap aesthetic, a cross hatch or a radial design, and the option of an alternating color scheme. Hollow cavity design made with PET felt allows for high-quality acoustic performance.

Application Acoustical Wall Tile

	L	W	H	WEIGHT
PLANK	45.5"	5.79"	.75"	0.7 lbs.
PLANK	45.5"	5.79"	1"	0.8 lbs.

Hardware

Default: Drywall Screws via patent pending Secret Trap Door

Default (Printed): Impaler Clip

* Liquid Nail or 3095 Carpet Glue Adhesive

(*) - Upon Request

Material Content 9 mm 100% PET (55% recycled content)

Fire Rating Class A per ASTM E-84, based on 9mm white

Acoustics

Frequency (Hz)	250	500	1K	2K	NRC
NRC	0.12	0.28	0.61	0.91	(0.30-0.75)
Sabins per m ²	0.81	1.89	4.20	6.18	

Test was conducted while product was in its actual installation setting.

All NRC testings assumes one face/one object and does not account for the product thickness.

Environment

Low VOC;
Post-Consumer Recycled Content
100% Recyclable

Installation

PLANK comes in two different thickness elevations. Simply plan your layout area and mount PLANK through our patent pending Secret Trap Door directly onto your wall surface. The Secret Trap Door will leave PLANK with a seamless surface after installation.

Country of Origin

USA

Warranty

2 Years

PLANK

DIMENSIONS & HARDWARE DETAILS

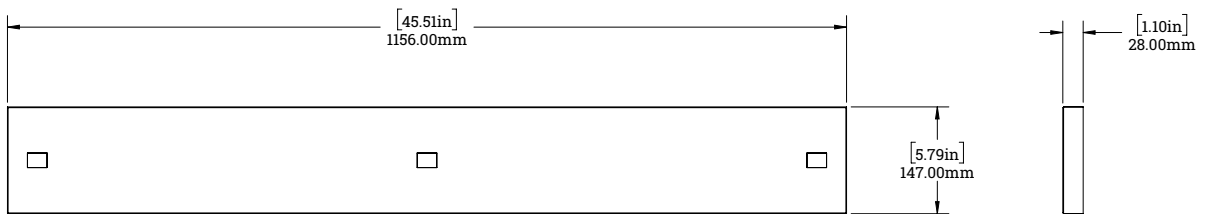
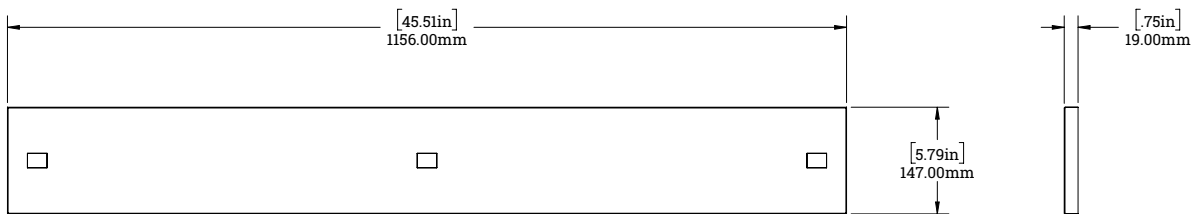
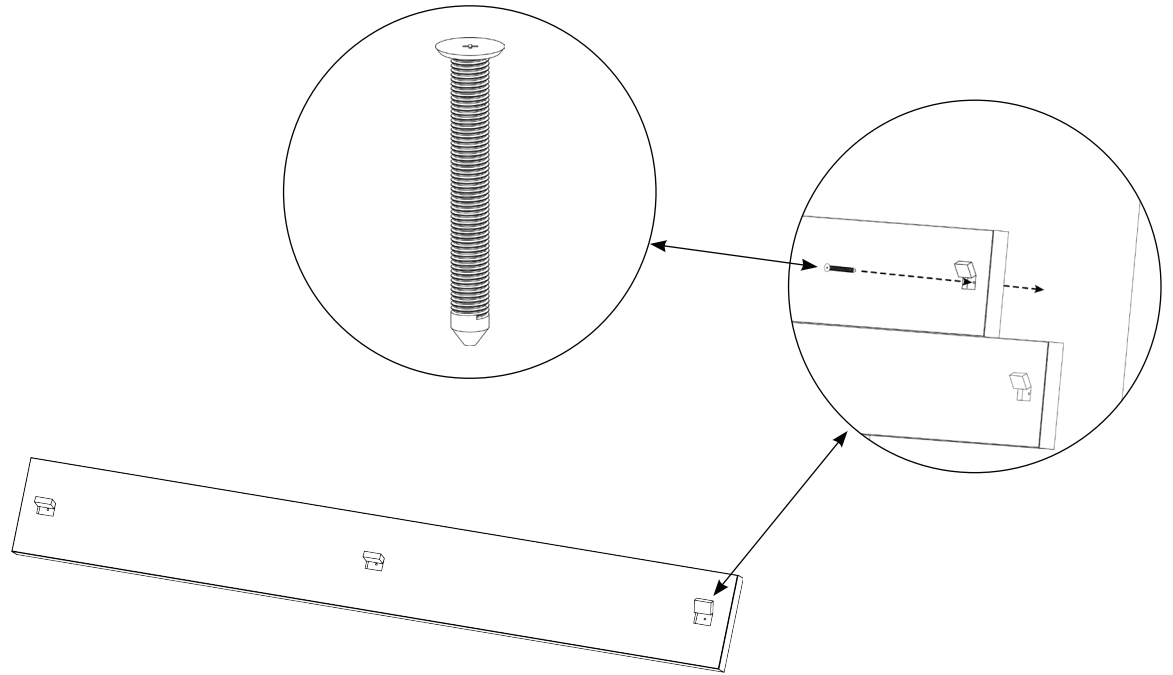

PLANK (PRINTED)

INSTALLATION & HARDWARE DETAILS

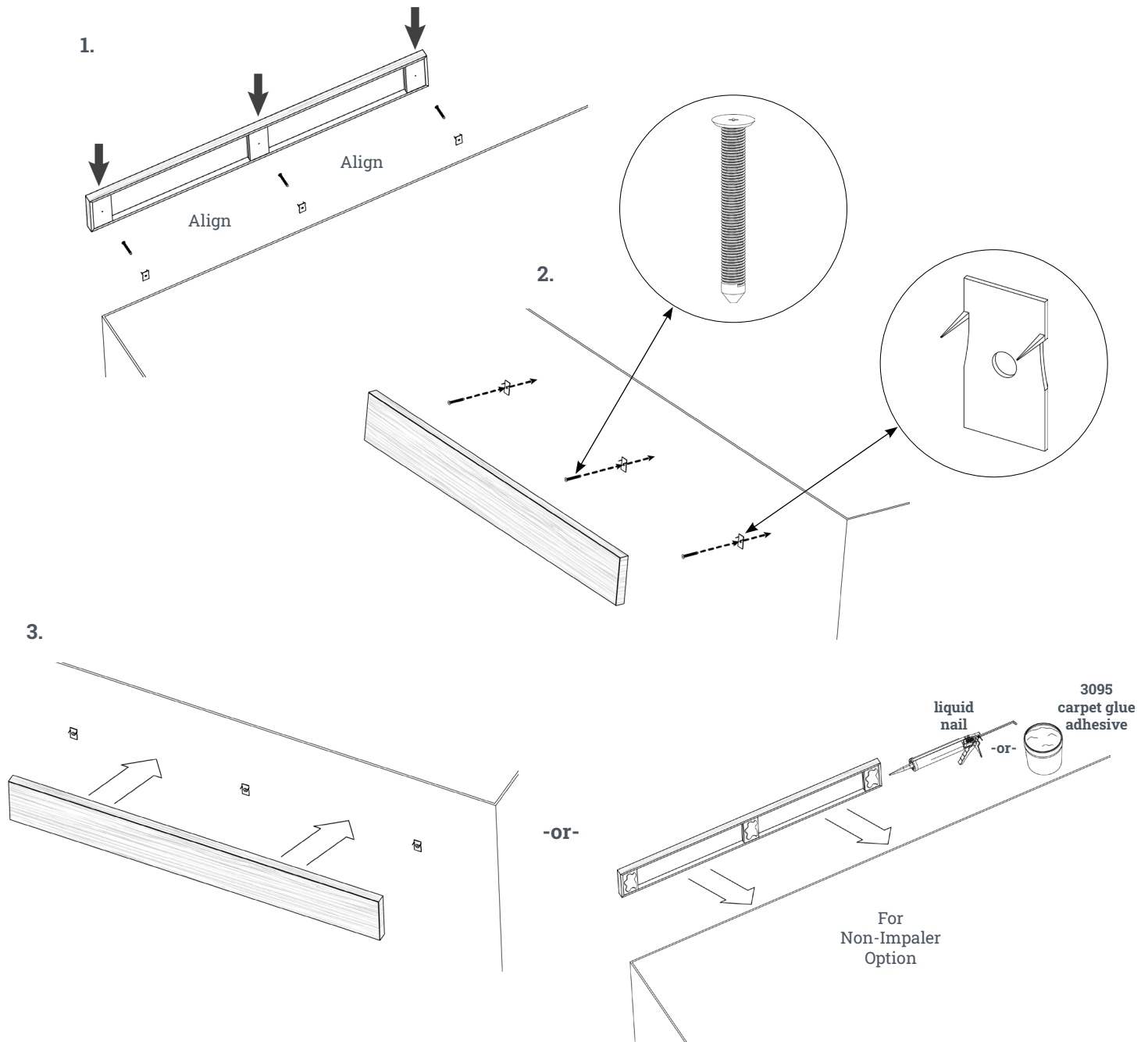

PLANK

WALL LAYOUT

